



SAP DIN Optimised is a series of light weight casing piston pumps with a fixed displacement for demanding mobile hydraulics. It is variant of the standard SAP series, also suitable for electric motor drives due to the pump's higher speed properties and lower noise level.

SAP 012-108 DIN Optimised covers the displacement range 12-108 cm³/rev. at a maximum pressure of 400 bar. It is a modern, compact pump which meets the market's high demands on flow performance, pressure, efficiency and small installation dimensions. It is either mounted directly on the power take-off or on a frame bracket via an intermediate shaft.

The optimised option gives a more silent operation with higher pump speeds. It is a speed-optimised pump and therefore supplied for either left (L) or right (R) rotation direction.

Other advantages:

- Less noise than the standard SAP series
- Less pulsations in the system
- Smooth operation over the entire speed range
- Long life due to high demands on material selection, such as bearings, seals, etc
- Corrosion free light metal-housing
- Less heat generation due to better ability to dissipate heat through housing

Versions, main data

Example

| | | | | | | | | | | | | | | | | |
|------|---|---|-----|---|---|---|---|-----|---|-----|---|----|---|---|---|----|
| SA | P | - | 084 | L | - | N | - | DL4 | - | L35 | - | S0 | S | - | 2 | 00 |
| Line | 1 | | 2 | 3 | | 4 | | 5 | | 6 | | 7 | 8 | | 9 | 10 |

| | |
|------|------------------|
| Line | |
| SA | Sunfab Aluminium |

| | |
|---------|------|
| 1. Type | |
| P | Pump |

| | | | | | | | | | |
|-----------------|-----|-----|-----|-----|-----|-----|-----|-----|-----|
| 2. Displacement | | | | | | | | | |
| 012 | 017 | 025 | 034 | 040 | 047 | 056 | 064 | 084 | 108 |

| | |
|--------------------------|-------|
| 3. Direction of rotation | |
| R | Right |
| L | Left |

| | |
|---------------|---------|
| 4. Shaft seal | |
| N | Nitrile |
| V* | HNBR |

*Can withstand higher temperature, e.g. on engine PTO. Not available for 012-034.

| | |
|--------------------|---------------------|
| 5. Mounting flange | |
| DL4 | DIN 4-h (ISO 7653D) |

| | |
|----------|--------------------------|
| 6. Shaft | |
| L35 | DIN 5462 / ISO 14 |
| H35 | DIN 5462 / ISO 14 Ø 8.15 |

| | |
|---------------------|---------------------|
| 7. Connection cover | |
| S0 | 40° Sunfab standard |

| | |
|----------------|-----------------|
| 8. Connections | |
| S | Sunfab standard |

| | |
|---------------|--------------------------------|
| 9. Additional | |
| 2 | Optimised |
| 3 | Optimised + External drainage* |

*Only available for 084 & 108. See separate brochure "Injector" for more information.

| | |
|-----------------|--------------------------|
| 10. Accessories | |
| 00 | No accessories available |

| SAP 012-108 DIN Optimised | | 012 | 017 | 025 | 034 | 040 | 047 | 056 | 064 | 084 | 108 |
|---|------|------|------|------|------|------|------|------|------|------|-------|
| Theoretical oil flow l/min at pump speed | | | | | | | | | | | |
| rpm | 500 | 6 | 9 | 13 | 17 | 21 | 24 | 28 | 32 | 42 | 54 |
| | 1000 | 13 | 17 | 25 | 34 | 41 | 47 | 57 | 64 | 84 | 108 |
| | 1500 | 19 | 26 | 38 | 51 | 62 | 71 | 85 | 95 | 125 | 162 |
| Displacement | | | | | | | | | | | |
| cm ³ /rev | | 12.6 | 17.0 | 25.4 | 34.2 | 41.2 | 47.1 | 56.7 | 63.6 | 83.6 | 108.0 |
| Max pump speed | | | | | | | | | | | |
| <i>continuous</i> | rpm | 3000 | 3000 | 2500 | 2500 | 2000 | 2000 | 2000 | 2000 | 1800 | 1800 |
| <i>intermittent</i> | | 3500 | 3500 | 3200 | 3200 | 2600 | 2600 | 2600 | 2600 | 2300 | 2300 |
| Max working pressure | | | | | | | | | | | |
| bar | | 400 | 400 | 400 | 400 | 400 | 400 | 400 | 400 | 400 | 400 |
| Weight | | | | | | | | | | | |
| kg | | 6.9 | 6.9 | 7.1 | 7.1 | 9.8 | 9.8 | 9.8 | 9.8 | 13.9 | 13.9 |
| Tare-weight torque (M) | | | | | | | | | | | |
| Nm | | 6.7 | 6.7 | 7.0 | 7.0 | 11.5 | 11.5 | 11.5 | 11.5 | 18.5 | 18.5 |
| Direction of rotation | | | | | | | | | | | |
| Left (L) or Right (R) | | | | | | | | | | | |

Noise levels compared to SAP standard pump

Measured at 200 bar

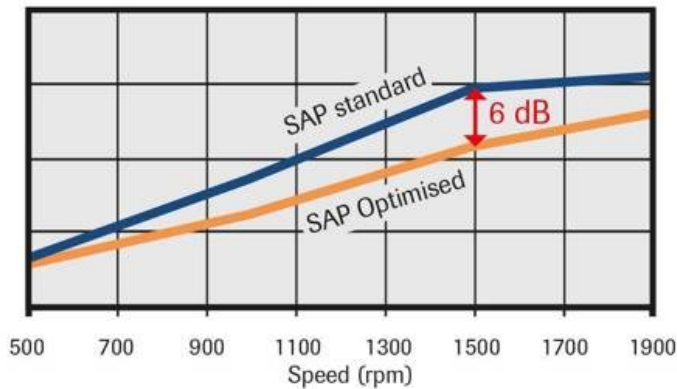

Dimensions SAP 012-034 DIN

Millimeter (inch)

DL4 ISO 7653-D

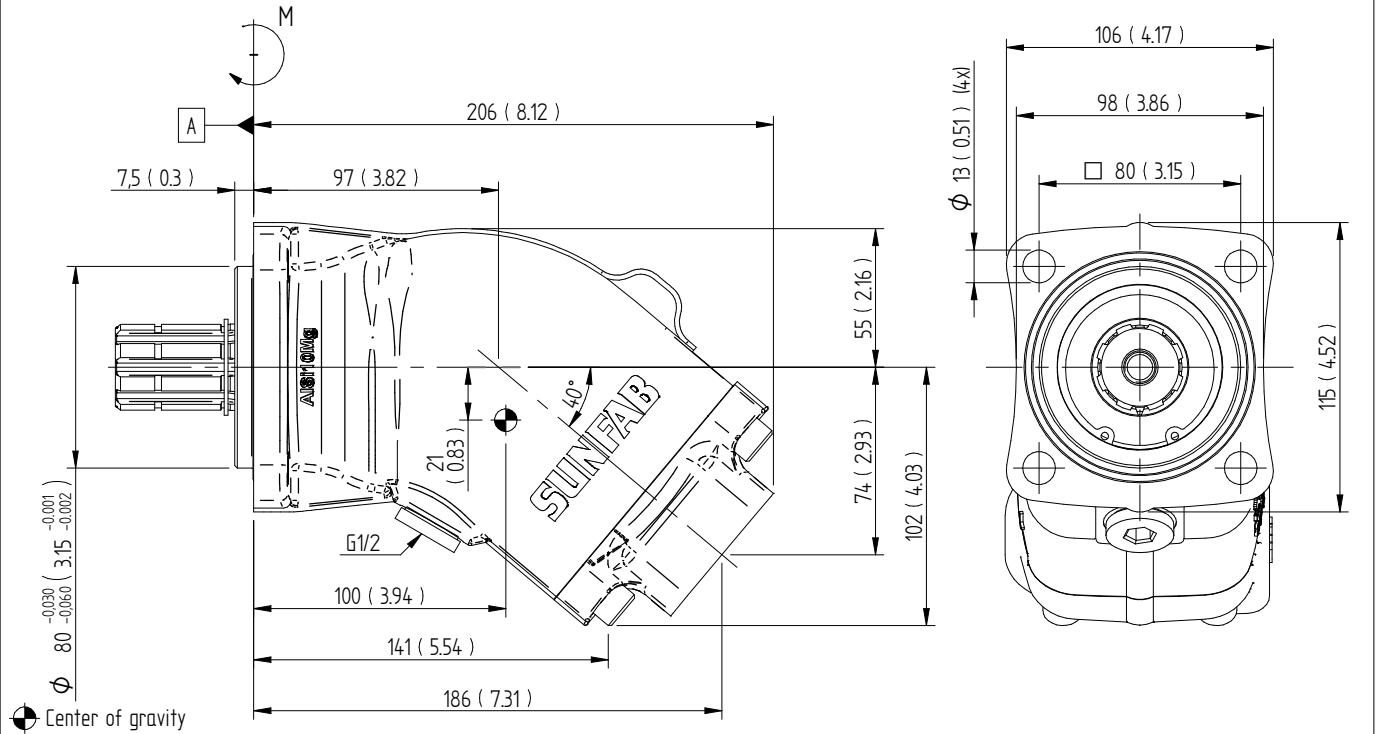

L35 DIN 5462 / ISO 14

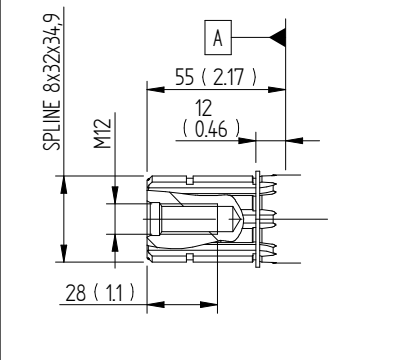

S0S Left rotation (L)

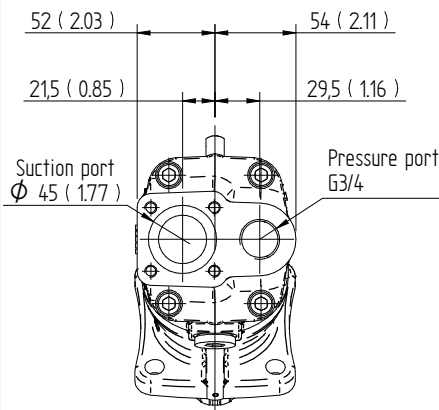

S0S Right rotation (R)

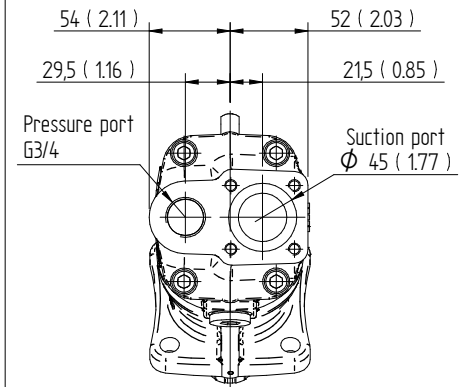

H35 DIN 5462 / ISO 14

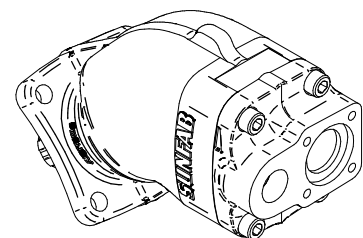
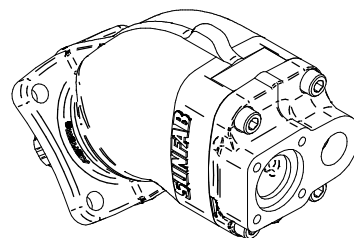
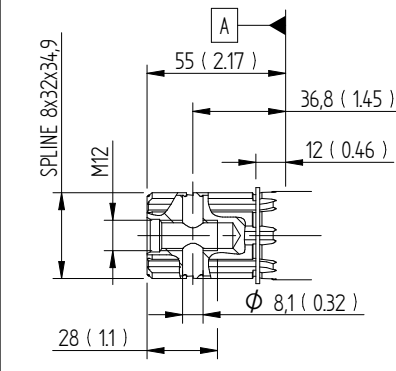

Dimensions SAP 040-064 DIN

Millimeter (inch)

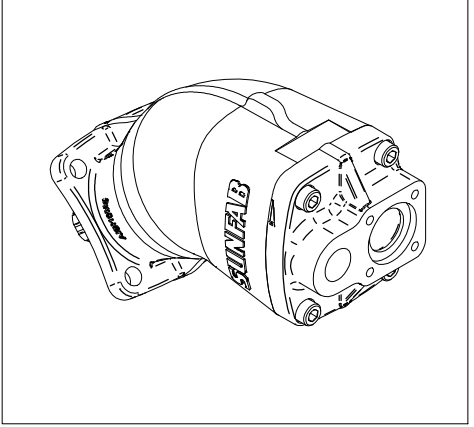
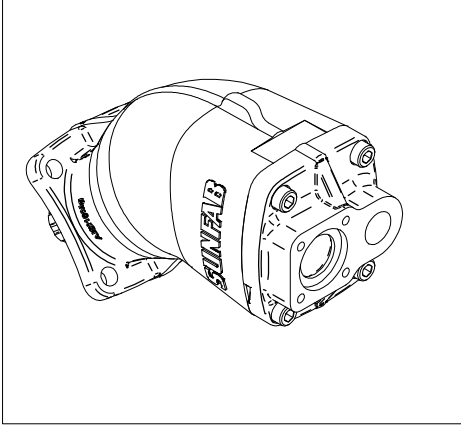
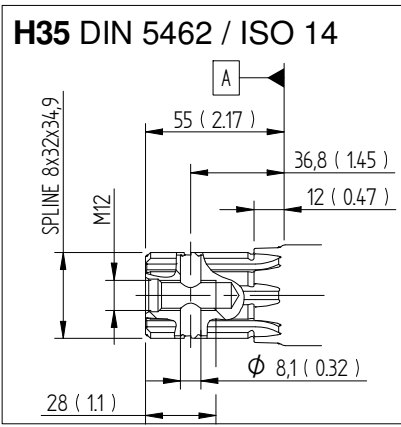
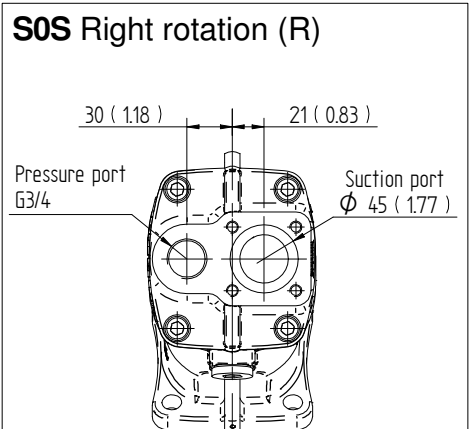
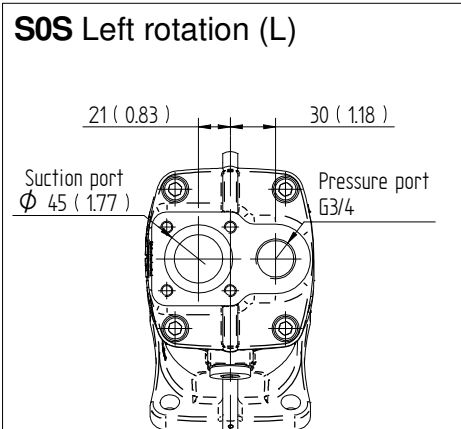
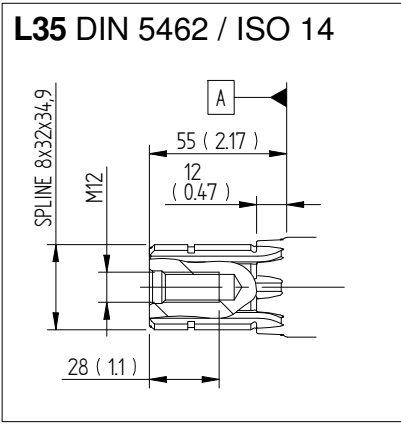
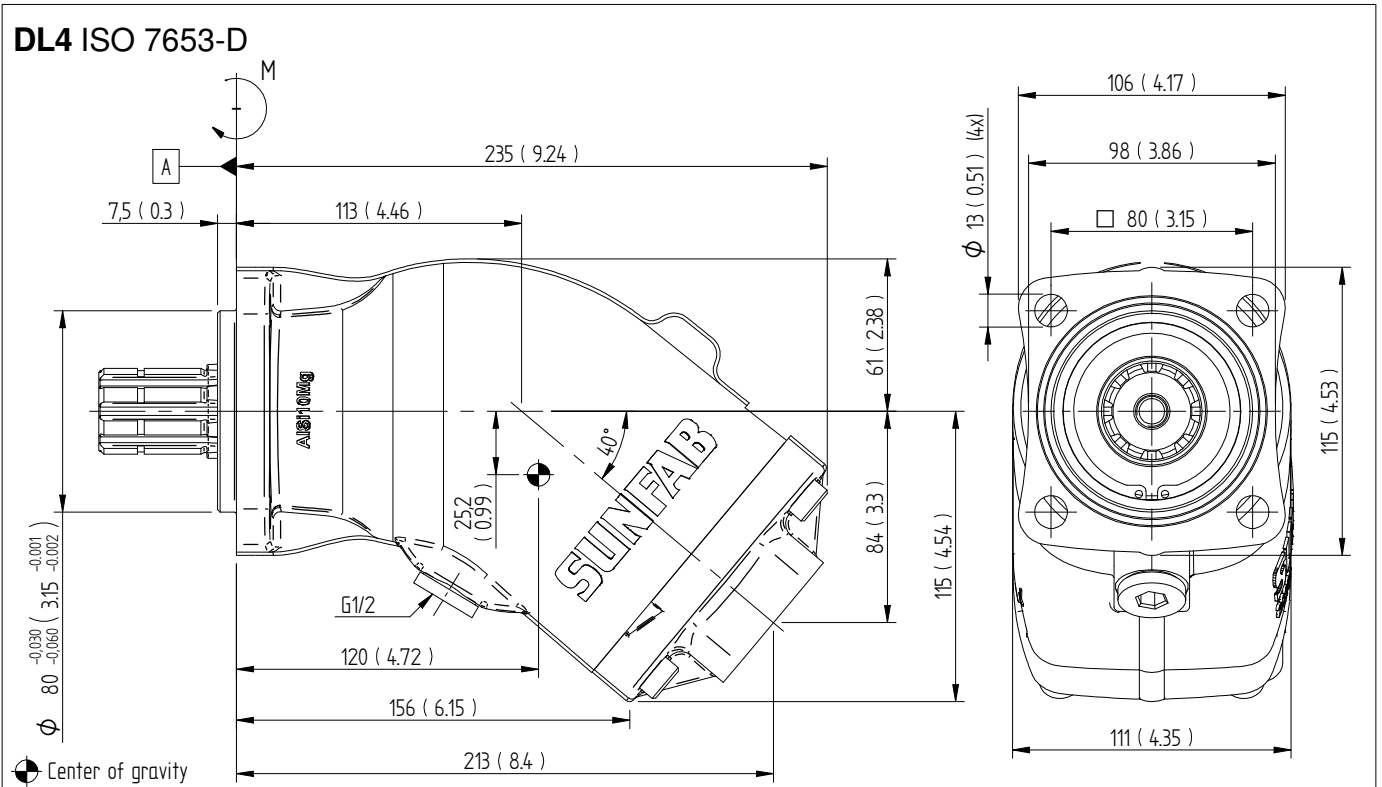

Dimensions SAP 084-108 DIN

Millimeter (inch)

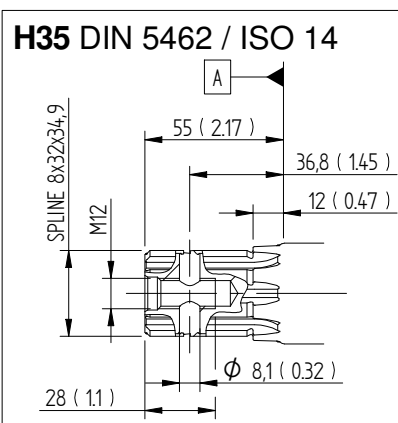
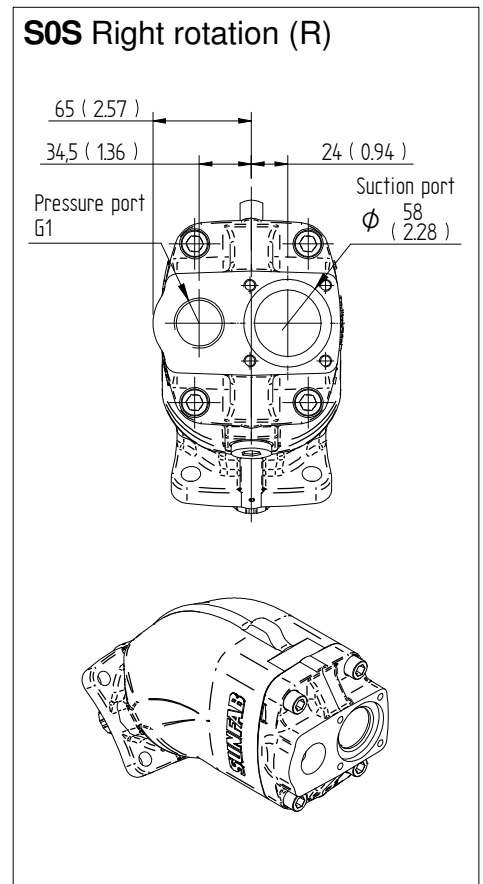
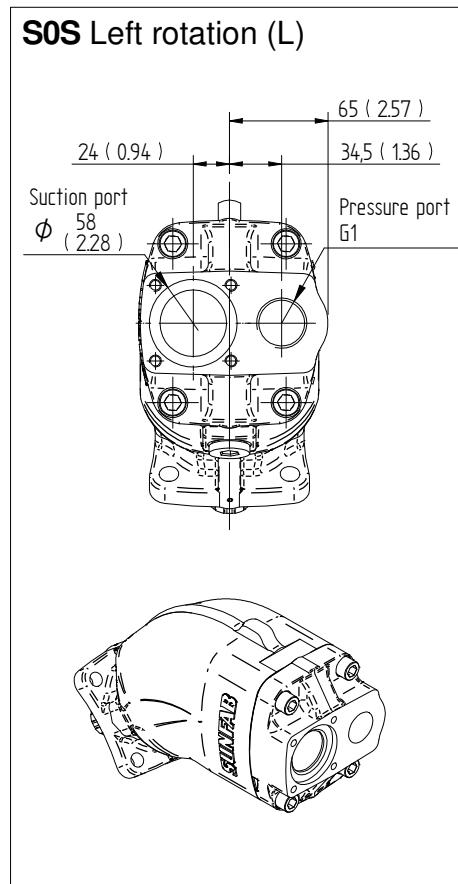
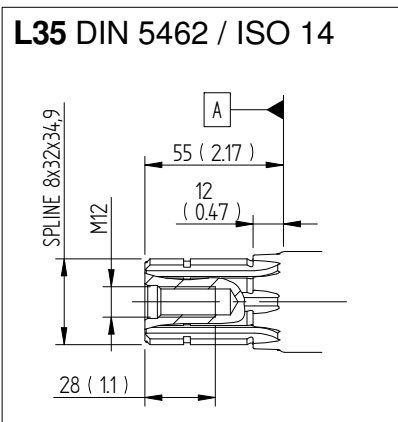
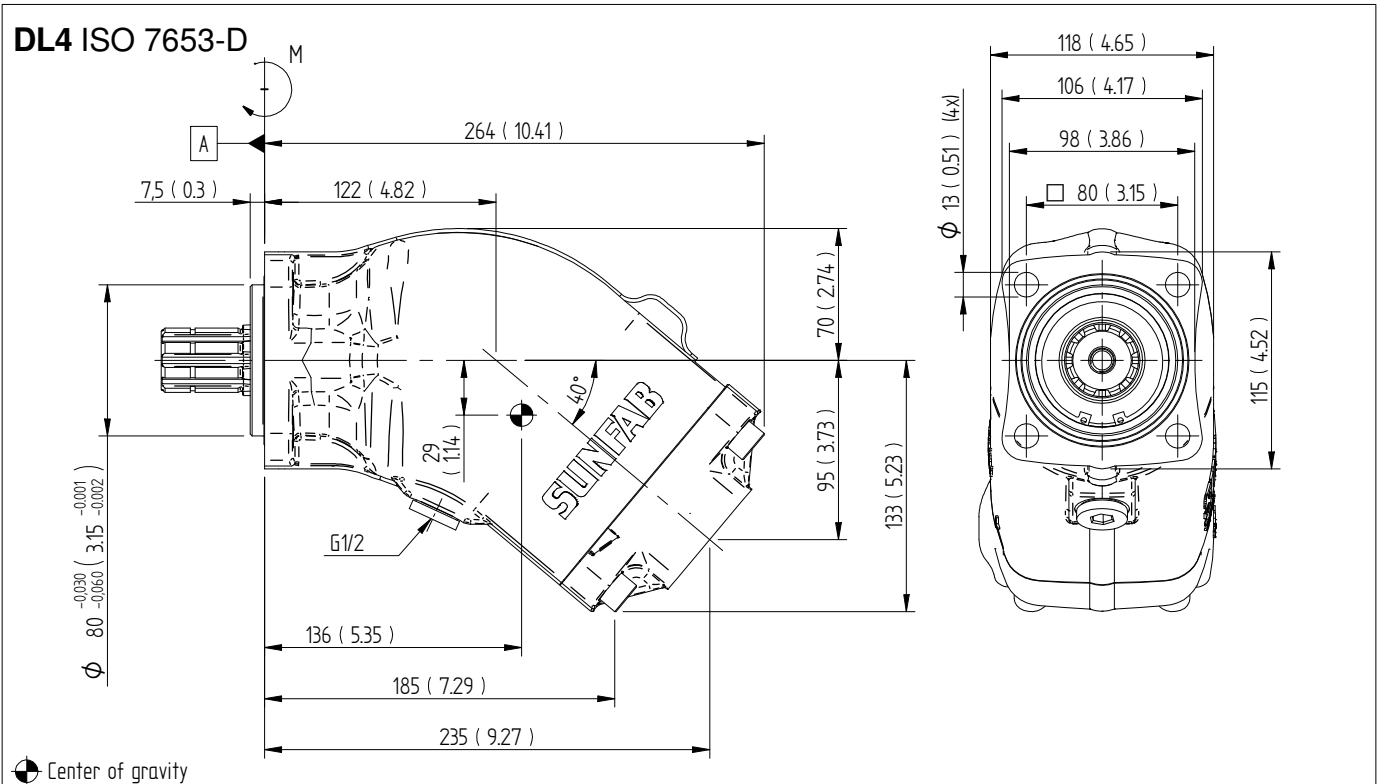



WARNING!

When the pump is running:

1. Do not touch the pressure hose
2. Watch out for rotating parts
3. The pump and hoses may be hot

Sunfab reserves the right to make changes in design and dimensions without notice. Printing and typesetting errors reserved.

© Copyright 2023 Sunfab Hydraulics AB. All Rights Reserved.