



SCM 025-108 M2 is a range of robust axial piston motors with cartridge flange especially suitable for winch-, slewing-, wheel- and track drives.

SCM 025-108 M2 is of the bent-axis type with spherical pistons. The design results in a compact motor with few moving parts, high starting torque and high reliability. The SCM 025-108 M2 covers the entire displacement range 25-108 cm³/rev. at a maximum pressure of 400 bar. The motors well dimensioned, double tapered roller bearings permit high shaft loads and lead to excellent speed characteristics. The high level of reliability is based on the choice of materials, hardening methods, surface structures and the quality assured manufacturing process.

Other advantages:

- High maximum speed
- Smooth operation over the entire speed range
- High efficiency
- Suitable for applications with high angular accelerations due to its high rotary stiffness

Versions, main data

Example

SC	M	-	025	W	-	P	-	M21	-	W30	-	V2	M	-	1	00
Line	1		2	3		4		5		6		7	8		9	10

Line

SC	Sunfab Compact, bent-axis design
----	----------------------------------

1. Type

M	Motor
---	-------

2. Displacement

025	034	040	047	056	064	084	090	108
-----	-----	-----	-----	-----	-----	-----	-----	-----

3. Direction of rotation

W	Independent
---	-------------

4. Shaft seal

P	FPM, high pressure, high temperature
---	--------------------------------------

For low temperature applications, below -25 °C please contact Sunfab.

5. Mounting flange

		025	034	040	047	056	064	084	090	108
M21	∅ 135	X	X	-	-	-	-	-	-	-
M22	∅ 160	-	-	X	X	X	X	-	-	-
M23	∅ 190	-	-	-	-	-	-	X	X	X

- = Not available

X = Standard, preferred

6. Shaft

Spline DIN 5480		025	034	040	047	056	064	084	090	108
W30	W30x2x14x9g	X	X	X	X	X	(X)	-	-	-
W35	W35x2x16x9g	-	-	X	X	X	X	X	X	X
W40	W40x2x18x9g	-	-	-	-	-	-	X	X	X

- = Not available

X = Standard, preferred

(X) = Limited maximum pressure, contact Sunfab

7. Connection cover

		025	034	040	047	056	064	084	090	108
V1	90° Mount flange vertical*	-	-	-	-	-	-	X	X	X
V2	90° Mount flange horizontal*	X	X	X	X	X	X	X	X	X
K3	Combicover 90° side conn. thread	X	X	-	-	-	-	-	-	-

*According to SAE J518 code 62

8. Connections

		025	034	040	047	056	064	084	090	108
M	Metric*	X	X	X	X	X	X	X	X	X
G	ISO G**	X	X	-	-	-	-	-	-	-
U	UN***	X	X	X	X	X	X	X	X	X

*Only flanged connections

**Only threaded connections

***Not available for K3

9. Additional

1	External drainage
---	-------------------

10. Speed Sensor

00	No Speed Sensor
----	-----------------

SCM 025-108 M2		025	034	040	047	056	064	084	090	108
Displacement										
cm ³ /rev		25.4	34.2	41.2	47.1	56.7	63.5	83.6	90.7	108.0
Working pressure										
bar	<i>max intermittent</i>	400	400	400	400	400	400	400	400	350
	<i>max continuous</i>	350	350	350	350	350	350	350	350	300
Revolutions										
rpm	<i>max intermittent</i>	7000	7000	6300	6300	6300	6300	5200	5200	5200
	<i>max continuous</i>	6300	6300	5700	5700	5700	5700	4700	4700	4700
	<i>min continuous</i>	300	300	300	300	300	300	300	300	300
Max power										
kW	<i>max intermittent</i>	86	115	125	145	175	195	215	230	230
	<i>max continuous</i>	40	55	60	65	80	90	100	110	110
Starting torque theoretical value										
Nm/bar		0.40	0.54	0.66	0.75	0.89	1.00	1.33	1.44	1.71
Moment of inertia (x 10⁻³)										
kg m ²		1.1	1.1	2.6	2.6	2.6	2.6	7.4	7.4	7.4
Weight										
kg		11.0	11.0	18.3	18.3	18.3	18.3	26.0	26.0	26.0

Data concerning RPM are based on maximum permitted peripheral velocity of the tapered roller bearing.

Max intermittent power data may vary dependent on application. For further information please contact Sunfab.

Continuous power data are based on maximum output power without external cooling of the motor housing.

Intermittent duty is defined as follows: max 6 seconds per minute, e.g. peak RPM when unloading or accelerating.

Dimensions SCM 025-034

Flange & shafts

Millimeter (inch)

M21

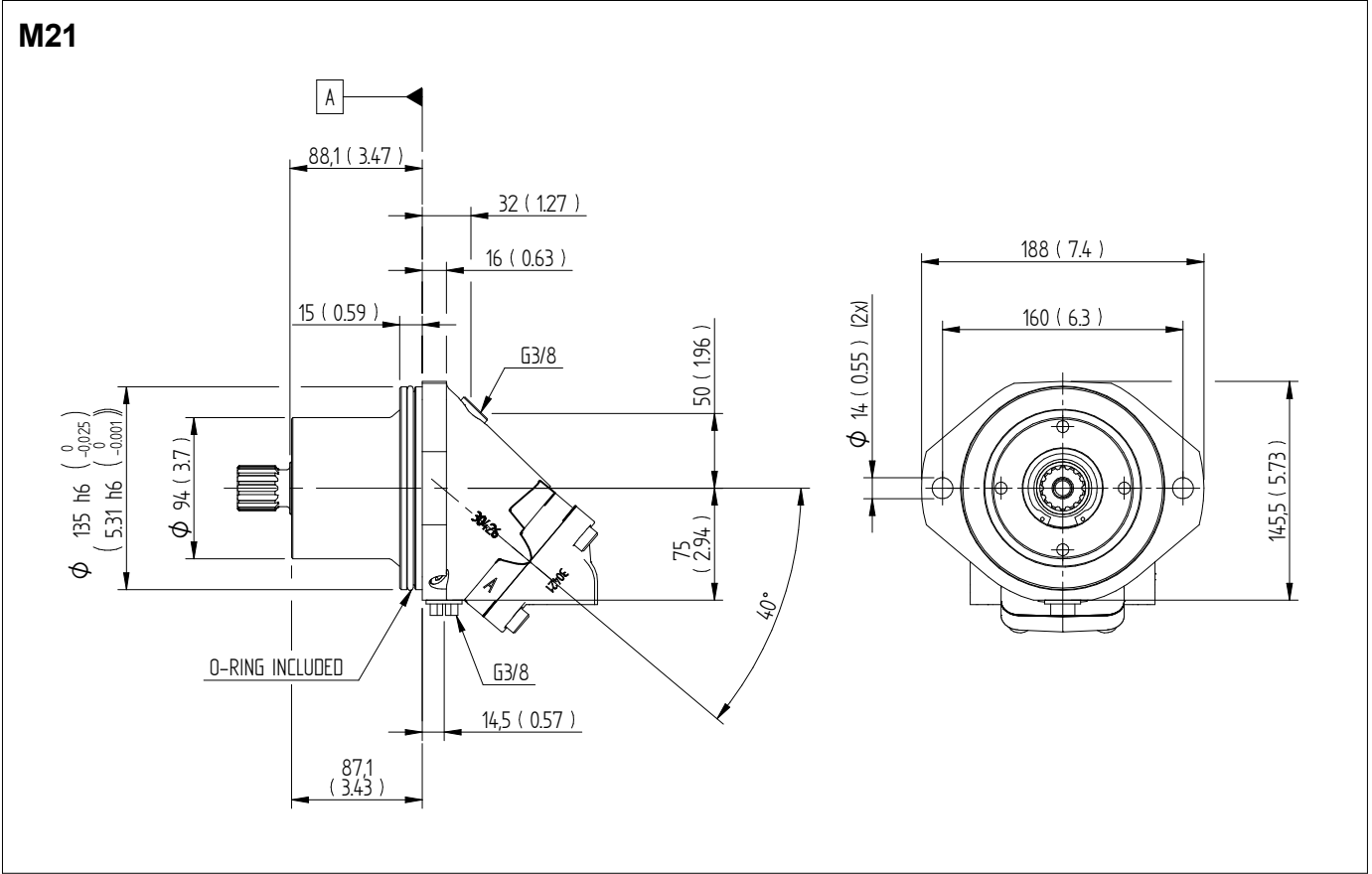

W30 DIN 5480

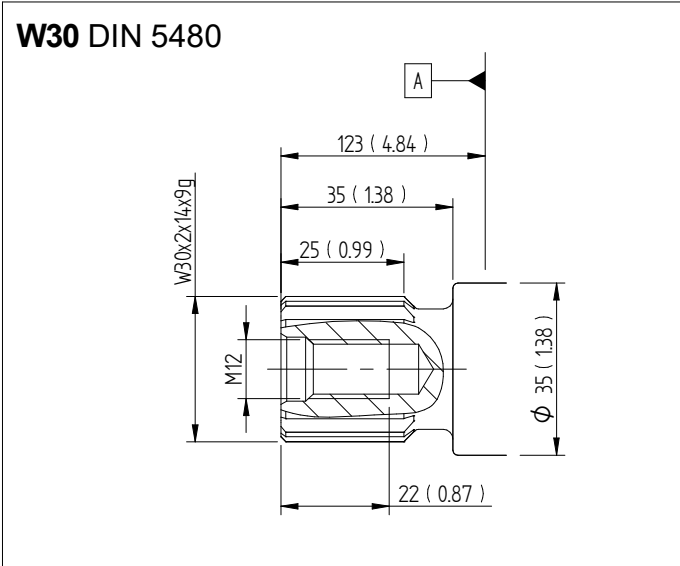

Dimensions SCM 025-034

Connection cover

Millimeter (inch)

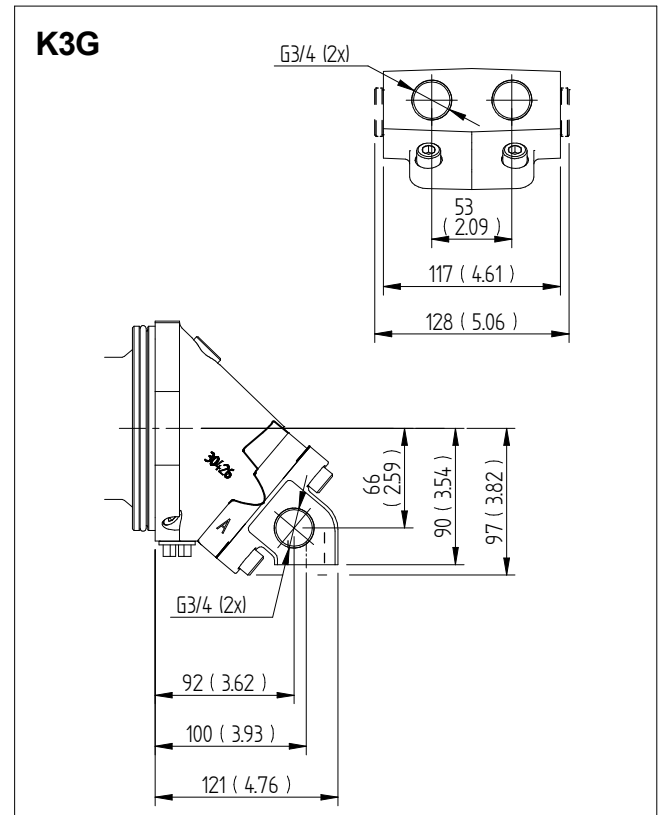
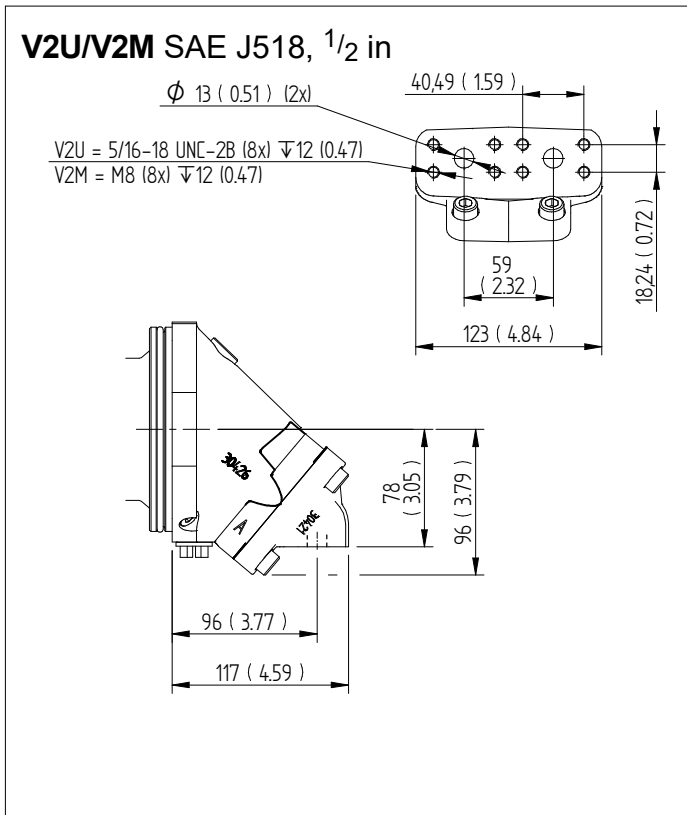

Dimensions SCM 040-064

Flange & shafts

Millimeter (inch)

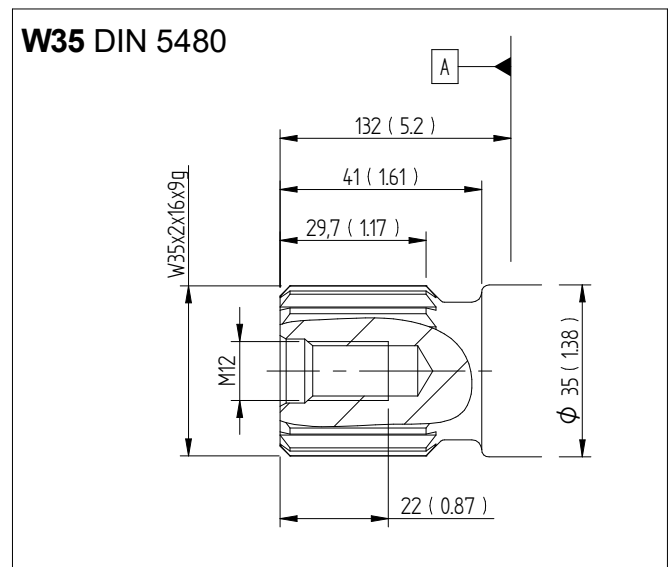
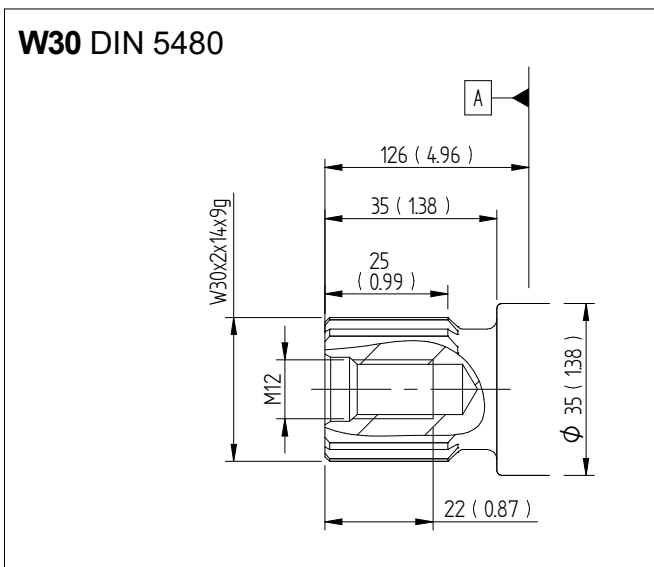
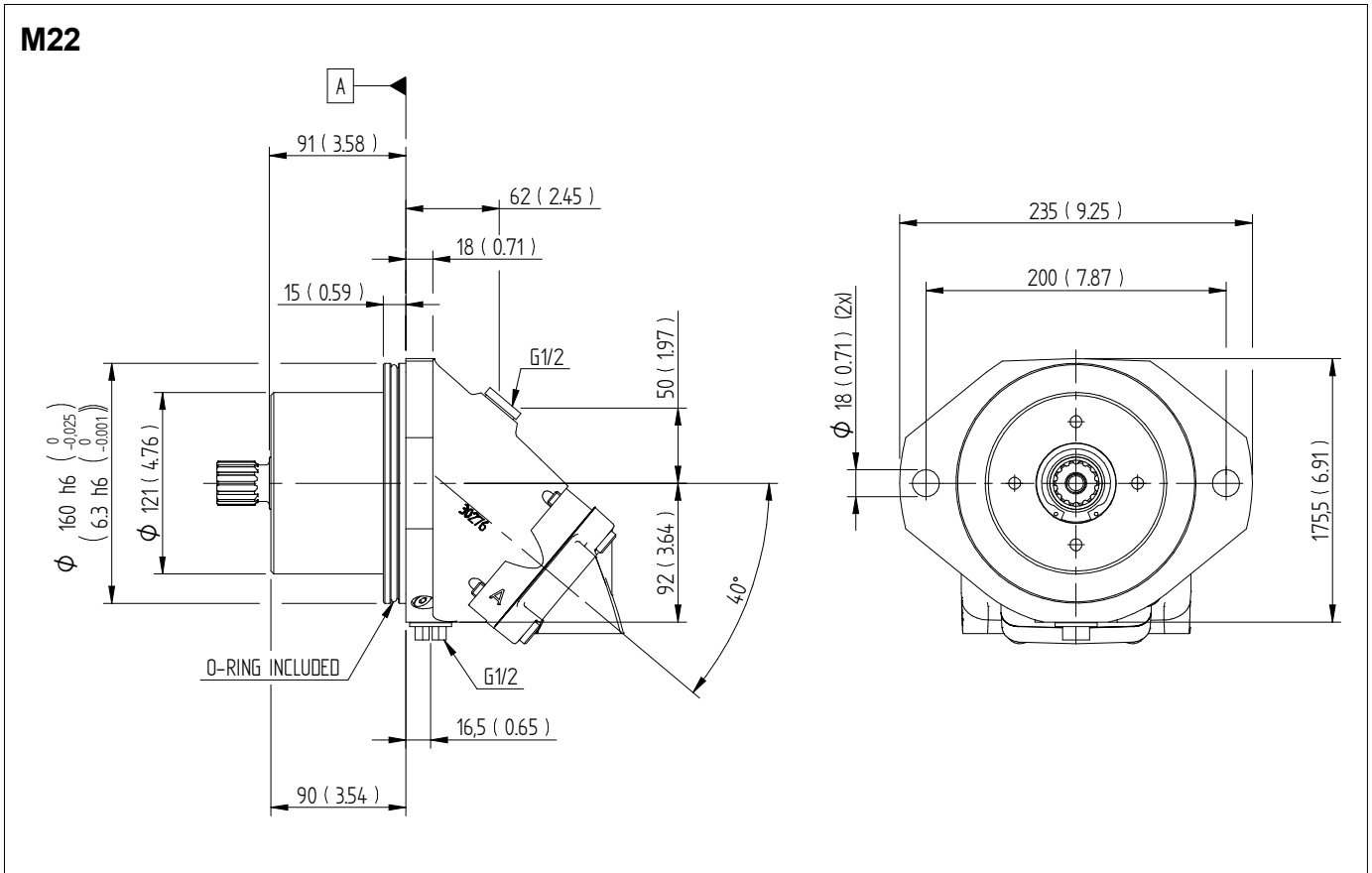

Dimensions SCM 040-064

Connection cover

Millimeter (inch)

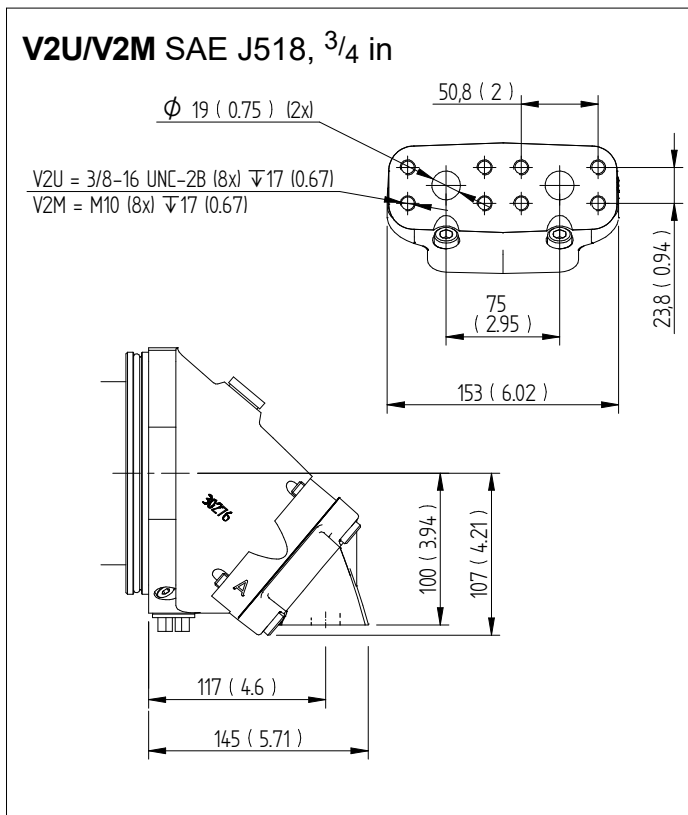

Dimensions SCM 084-108

Flange & shafts

Millimeter (inch)

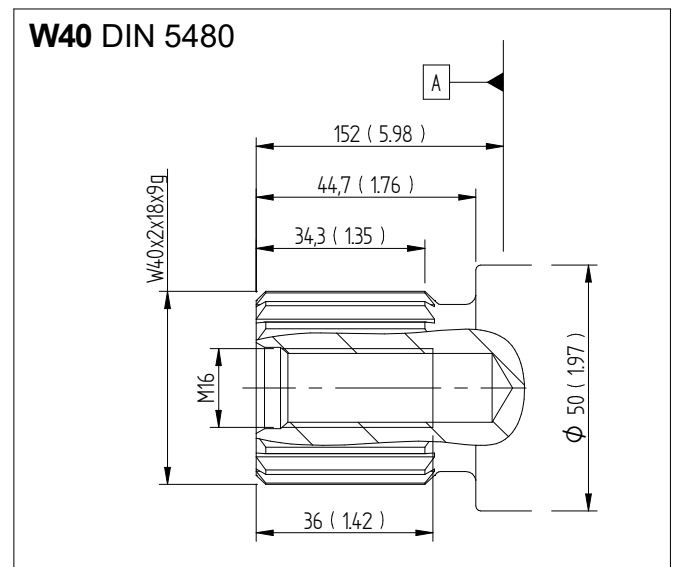
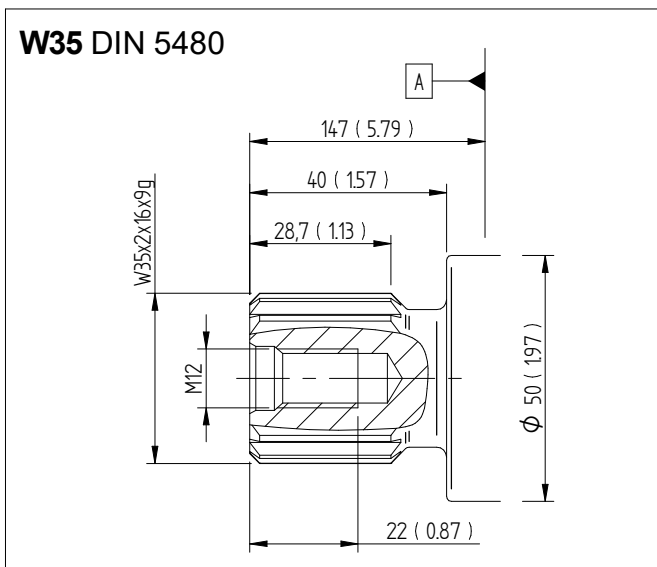
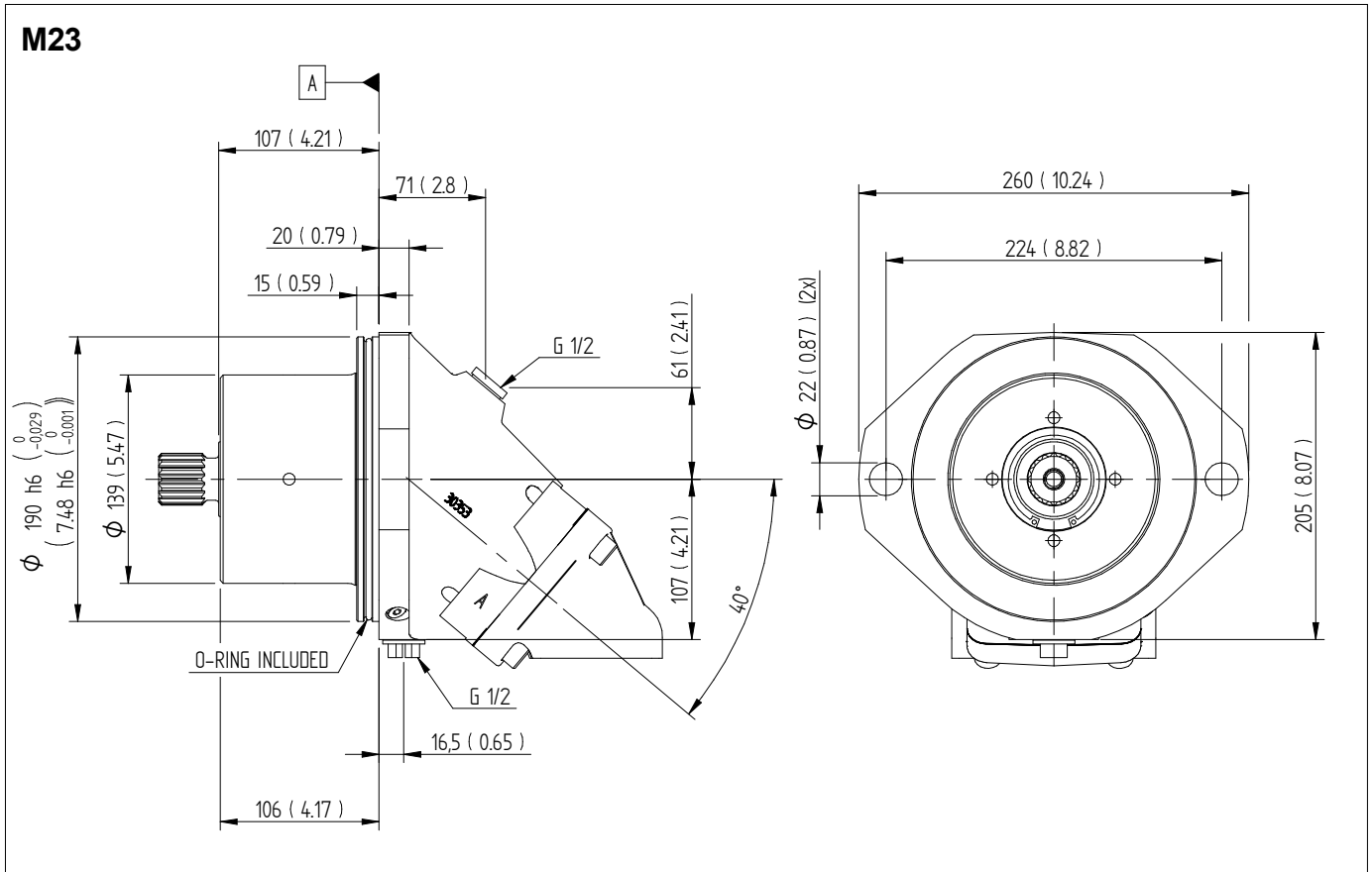

Dimensions SCM 084-108

Connection cover

Millimeter (inch)

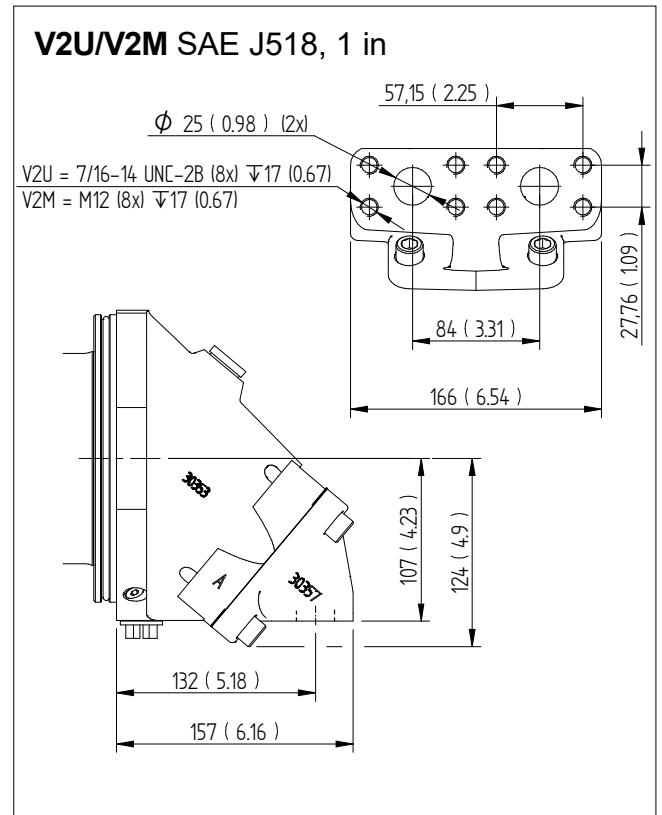
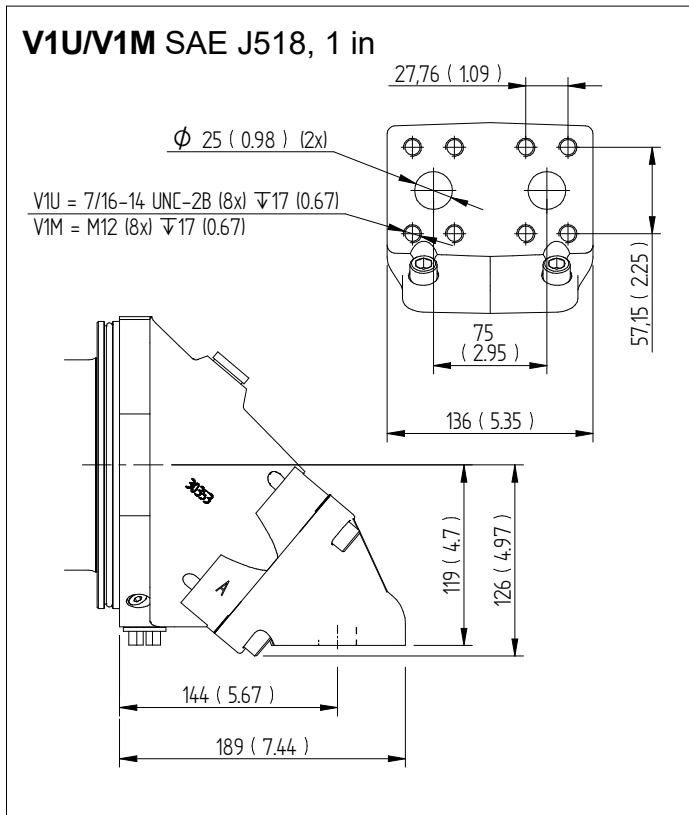

General instructions

Shaft seal

Motor SCM	Code	Max. housing pressure bar at rpm				
		1500	3000	5200	6300	7000
025-034	P	7	7	4	3.5	3
040-064	P	7	6	3.5	3	-
084-130	P	7	4	3	-	-

Code according to page 2. Versions main data.

For low temperature applications, below -25 °C please contact Sunfab.

The drainage oil should have a maximum temperature of 115 °C with the P shaft seal. This temperature must not be exceeded.

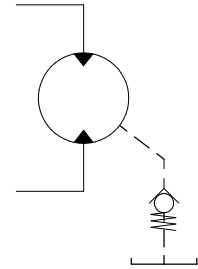

The housing pressure must be equal to or greater than the external pressure on the shaft seal.

To ensure the function of the shaft seal and lubrication of the motor, we recommend a min. housing pressure of 0,5 bar. If needed, a spring loaded check valve of 0,5 bar can be installed on the housing drain line.

Shaft loads

The life of the motor is highly dependent on the bearing life. The bearings are affected by operating conditions such as speed, pressure, oil viscosity and filtration.

External load on the shaft, as well as its size, direction and location also affects the bearing life.

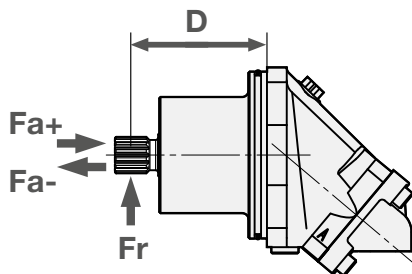

Optimal force direction of radial load

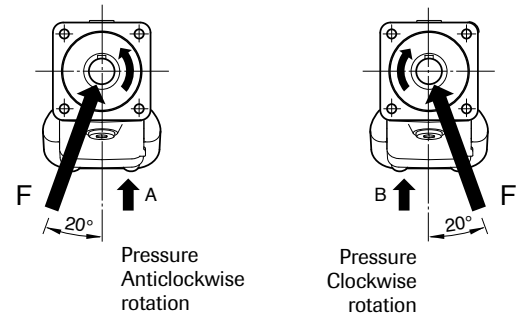

SCM M2 Max recommended shaft loads		025	034	040	047	056	064	084	090	108
Fr (radial) max ¹	kN	7.5	7.5	7.5	8	8.5	8.5	14.5	14.5	15
Distance D (to point of force)	mm	100	100	110	110	110	110	120	120	120
Fa (axial) + (at standstill/ 0 bar pressure) max	kN	3	3	4	4	4	4	5	5	5
Fa (axial) - (at standstill/ 0 bar pressure) max	kN	7	7	7	7	10	11	13	14	16
Fa (axial) + (at 400 bar pressure) max ²	kN	7	7	7	7	10	11	13	14	16
Fa (axial) - (at 400 bar pressure) max ²	kN	0	0	0	0	0	0	0	0	0

¹) Fr (radial) max; Calculation based on running conditions: 300 bar / 2000 rpm

¹) Fr (radial) max; Calculation based on optimal force direction (Fr max will be lower in other force directions)

¹) Fr (radial) max; In running conditions higher than 300 bar and/or 2000 rpm the max limits for Fr (radial) max will be lower

²) Fa (axial) + Will increase bearing life

²) Fa (axial) - Will decrease bearing life

For other forces, please contact Sunfab for advice.

Temperatures/Housing cooling

Excessive system temperature reduces the life of the shaft seal and can lower the oil viscosity below the recommended level. A system temperature of 60 °C and a drain flow temperature of 115 °C must not be exceeded.

Cooling/flushing of the motor housing can be needed to keep the drain flow temperature at an acceptable level.

Suggested flow:

Motor SCM	Flushing l/min	Cont. RPM
025-034	2-8	≥ 2800
040-064	4-10	≥ 2500
084-108	6-12	≥ 2200

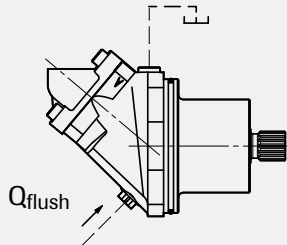

Housing flushing can be built up with the help of a flushing valve or taken directly from the return line. When the return pressure is too low this is compensated for by a counter pressure valve. The tank line is connected to the highest point as in the figure.

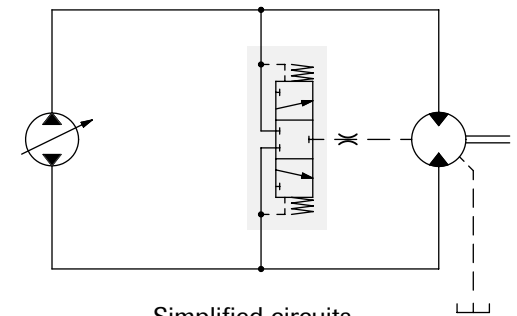
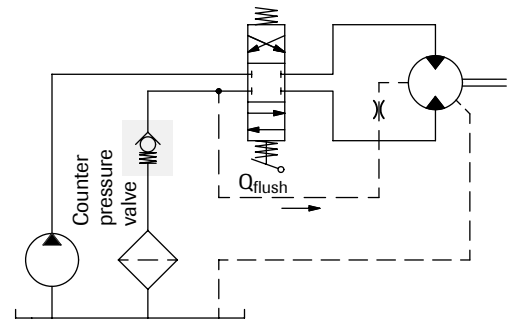
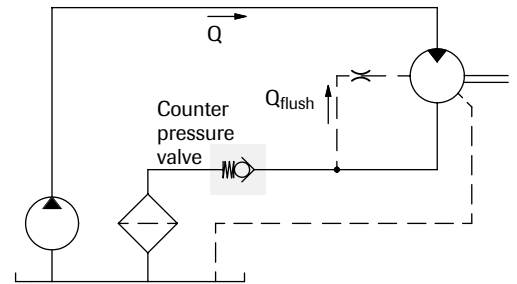

Simplified circuits

Installation

- The motor housing should be filled with oil to at least 50% before starting.
- The drainage pipe should be connected to topmost drainage outlet.
- The other end of the pipe should be connected to the oil tank at a point below the oil level.

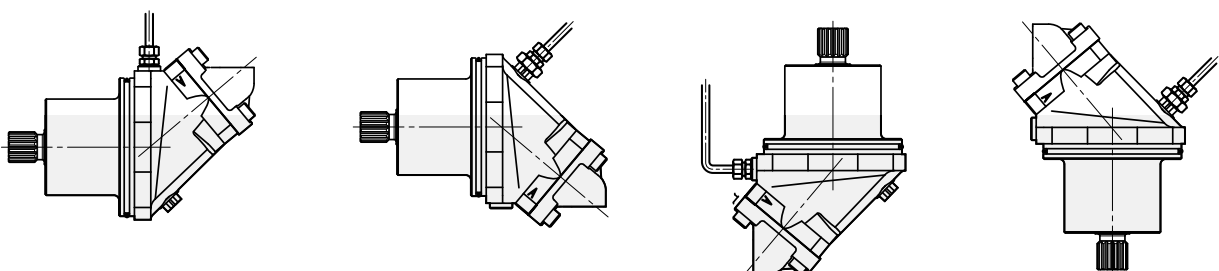

Piping

Recommended oil velocity in pressure line max. 7 m/sec

Filtering

Cleanliness according to ISO norm 4406, code 16/13.

Hydraulic fluids

High performance oils meeting ISO specifications – such as HM, DIN 51524-2 HLP, or better – must be used.

A min. viscosity of 10 cSt is required to keep the lubrication at a safe level.

The ideal viscosity is 20 - 40 cSt.

Additional technical data

Noise levels and bearing life calculations available on request. Please contact Sunfab!

Useful formulaes

$$\text{Required flow rate } Q = \frac{D \times n}{1000 \times \eta_v} \quad \text{litres/min.}$$

$$\text{Speed } n = \frac{Q \times 1000 \times \eta_v}{D} \quad \text{RPM}$$

$$\text{Torque } M = \frac{D \times \Delta p \times \eta_{hm}}{6.3} \quad \text{Nm}$$

$$\text{Power } P = \frac{Q \times \Delta p \times \eta_t}{60} \quad \text{kW}$$

D = displacement, cm³/revolution

n = speed, revolution/min

P = power, kW

Q = flow rate, litres/min

η_v = volumetric efficiency

η_{hm} = hydraulic-mechanical efficiency

η_t = overall efficiency = $\eta_v \times \eta_{hm}$

M = torque, Nm

Δp = pressure difference between the hydraulic motor inlet and outlet, MPa



WARNING!

When the motor is in use:

1. Do not touch the pressure pipe
2. Watch out for rotating parts
3. The motor and pipes can reach high temperatures

Sunfab reserves the right to make changes in design and dimensions without notice. Printing and typesetting errors reserved.

© Copyright 2023 Sunfab Hydraulics AB. All Rights Reserved.